



User manual



BLO online analysing device **BLO wood chips sensor**

online analysing device for the determination
of water content of wood chips

Table of contents

1. General information	3
2. Design and mounting of the sensor	3
3. Installation instructions	4
4. Connecting sensor cable	5
5. Mounting the control unit	5
6. Cable assembly at the control unit	6
6.1 Option 24VDC power supply	6
6.2 Option 230VAC power supply	6
7. Start-up	7
7.1 Electrical grounding of the device	7
7.2 Switching on the instrument	7
8. Using the humimeter BLO	7
9. Calibration curves:	8
10. Calibration	8
11. Analogue output interfaces	9
12. Test block	9
13. Photos for selection of right calibration curve	10
14. Notes	12
15. Exemption from liability	13
16. Technical data	13
16.1. BLO material moisture sensor	13
16.2. humimeter BLO control unit	13
17. Device maintenance instructions	13
18. Most common reasons for miss readings	14

1. General information

The measuring system BLO allows an online measurement of moisture content and temperature of the product. Therefore a fixed sensor is embedded in the material stream. According to the customer's demand and requirement profile different sensors (for determining as absolute moisture, relative air humidity, material temperature) can be used. The humimeter BLO control unit calculates the measuring values and shows them on a display. The moisture content and the temperature of the material is transmitted by 4 to 20mA analogue outputs.

2. Design and mounting of the sensor

Fix the sensor using the four holes ($\varnothing 9$ mm). Note the correct flow direction as shown on the picture. Take care that the two metal sheets have constant contact with the wood chips. This is essential to ensure correct measuring results.



Flow direction of wood chips

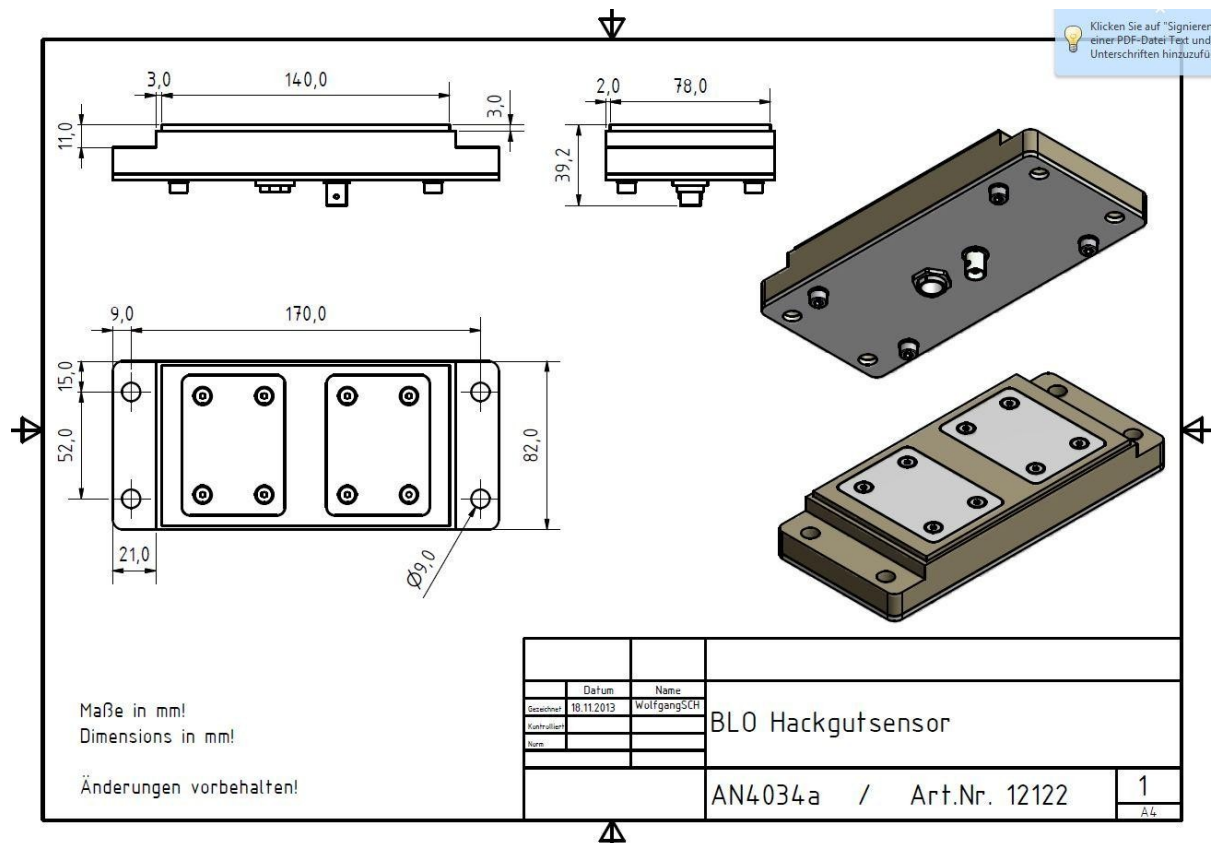

3. Installation instructions

Requirements:

During the measurement, the two stainless metal sheets have to have constant contact with the product (wood chips). To ensure correct measuring results, the wood chips have to exert a minimum pressure of 20 N/dm² on the sensor surface. The sensor measures the material that directly touches the sensor field. It must be ensured that no electrically conductive material affects the sensor surface.

Possible installation positions:

- Screw conveyor:
installation at the bottom of the trough
- In-feed chute with hydraulic ram:
installation at the side wall
- Bunker:
installation at the side wall (to ensure the minimum pressure, the sensor possibly has to be mounted at an angle)

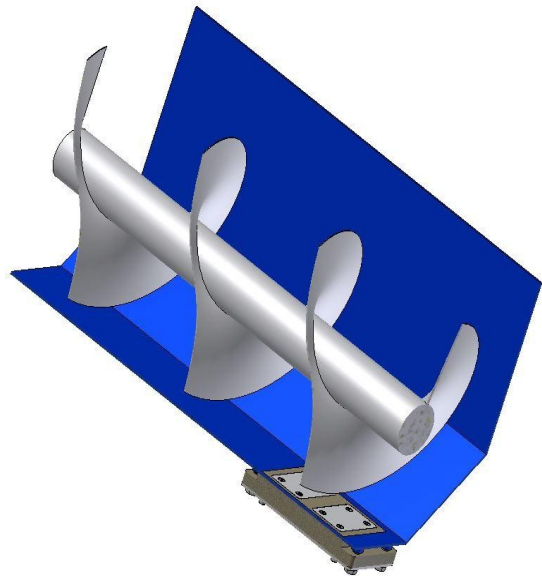

Measuring principle:

The BLO with wood chips sensor (art.no. 12122) uses a conductance measurement specially developed by Schaller GmbH. This principle is based on the fact that electrical conductivity changes according to the moisture content of a porous material. Electrical conductivity in dry material is lower than in wet material. The evaluation electronics converts the measured conductance value into weight percent and shows the water content on the display.

Information for installation after dryer:

After the drying process the material surface of the wood chips is much dryer than its core. Therefore an installation directly after the dryer will lead to too low measuring values. The specified minimum measuring range of 10% water content (for wood chips) will not be possible; in fact the measuring range limit is higher.

4. Connecting sensor cable

Connect the sensor cable to the BLO control unit and to the sensor as shown on the pictures.

There is a BNC and a push-pull connector. The push-pull connector has to be pushed into the socket.

To remove the connector pull the black jacket (1) away from the device.

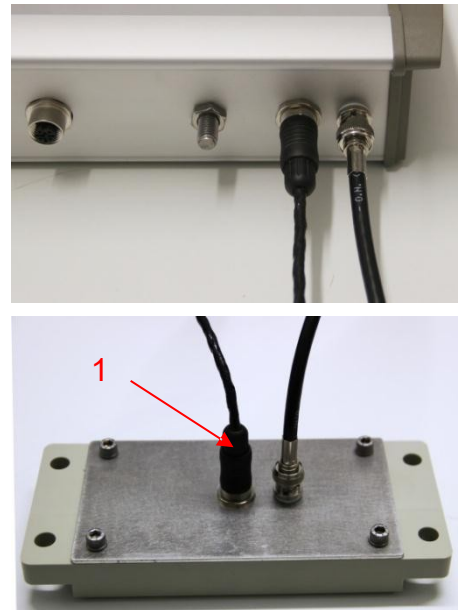

5. Mounting the control unit

Installation instructions according to the manufacturer!

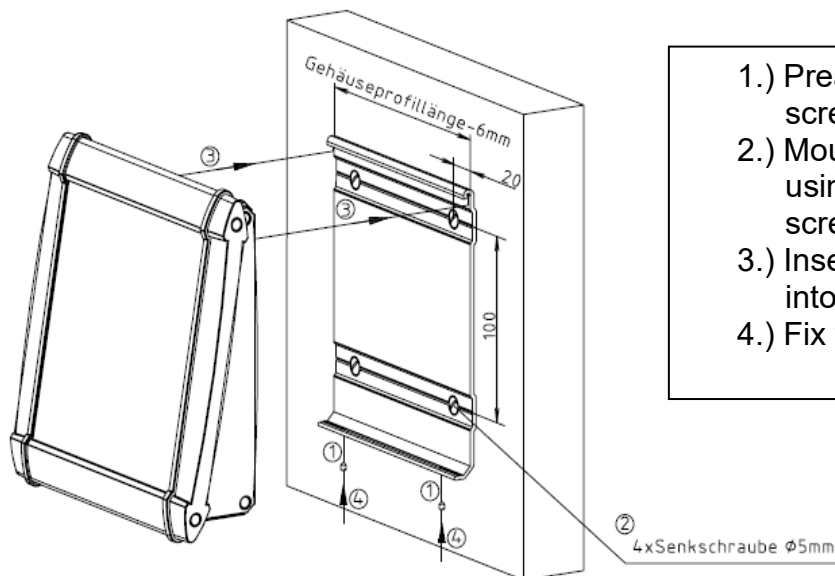

- 1.) Preassemble the grub screw
- 2.) Mount the wall holder using 4 counter sunk screws $d = 5\text{mm}$
- 3.) Insert the control box into the wall holder
- 4.) Fix the grub screw

6. Cable assembly at the control unit

6.1 Option 24VDC power supply

We deliver a special cable for power supply and analogue output. That cable has to be mounted to your BLO analysing unit as shown on the picture below (cable on the left side).



Connector pin assignment

white	24 VDC power supply (15 to 29VDC)
brown	ground power supply & analogue output
yellow/green	shield of cable
blue	analogue output water content 4 to 20mA
grey	analogue output temperature 4 to 20mA

For connecting with the analysing unit (PLC), a shielded cable with minimum wire of 0.25mm² has to be used.

The cable shield has to be grounded at the analysing unit (PLC)!



6.2 Option 230VAC power supply

The connection cable for power supply is already pre-mounted. Connect this cable to a standard safety socket (230VAC, 50Hz).

The analogue outputs have to be connected as described above, only the white wire is not connected at that option.

7. Start-up

7.1 Electrical grounding of the device

Connect a grounding cable to the control unit and to the grounding of your plant before starting the system.

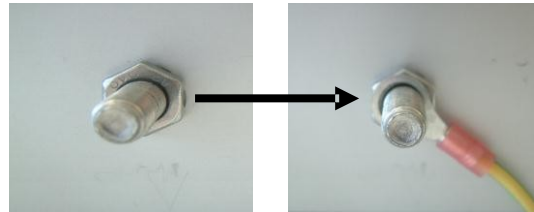



7.2 Switching on the instrument

Connect the sensor connector to the control unit (right female connector) and the power supply (left female connector). After connecting to the power supply, the humimeter BLO starts up with the logo and is then ready for use!



8. Using the humimeter BLO

1. Switch on the humimeter BLO by pressing the power button () for 3 seconds.
2. Select the right calibration curve for your material under test using the buttons  or .
3. Now the **measuring value** and the **temperature** are **shown on the display**.



9. Calibration curves:

name	description	measuring range
- wood chips	wood chips P16 - P31	10 to 55%
wood chips	wood chips P16 - P31	10 to 55%
+ wood chips	wood chips P16 - P31	10 to 55%
coarse wood chips	wood chips P45	10 to 55%
+ coarse wood chips	wood chips P45	10 to 55%
industrial wood chips	wood chips P63	10 to 55%
+ industrial wood chips	wood chips P63	10 to 55%
test block	internal curve	-----
reference	internal curve	-----

The test block and reference calibration curves are only determined for a device test and must not be used for measuring!

10. Calibration

The system is calibrated for standard woodchips according to class P16 up to class P63. In practice it may occur that the shown value differs from the real value. That indicates that the present material has a different “moisture calibration curve” than the type of material taken for calibration.

- **Wood chips:** wood chips of class **P16, P31** and **P45** (forest wood chips) according to norm EN ISO 17225-1
- **Coarse wood chips:** coarse wood chips of class **P31** or **P45** with **less fines** according to norm EN ISO 17225-1
- **Industrial wood chips:** industrial wood chips **without barks and fines**

Definition of wood chips classes (norm EN ISO 17225-1)

The stated numbers refer to the particle size that goes through round gaps of the corresponding diameters (ÖNORM M 7133).

- **P16 (G30)** minimum 75% of the bulk is between 3.15 and 16 mm
- **P31 (G50)** minimum 75% of the bulk is between 8 and 31.5 mm
- **P45 (G50)** minimum 75% of the bulk is between 8 and 45 mm
- **P63 (G100)** minimum 75% of the bulk is between 8 and 63 mm

11. Analogue output interfaces

The moisture content and material temperature values are transmitted continuously via the 4 to 20mA analogue outputs. Differences between analogue output and display are possible due to the resolution.

signal	type	minimum value	maximum value
moisture	4 to 20mA	4mA = 0%	20mA = 80%
temperature	4 to 20mA	4mA = -10°C	20mA = 70°C

12. Test block

Via the optionally available test block (article no. 12308) the operation and calibration of the BLO measuring system can be checked easily.

By pressing the test block on the stainless metal sensor sheets a fixed water content is simulated. Turning the test block, another fixed value is simulated.

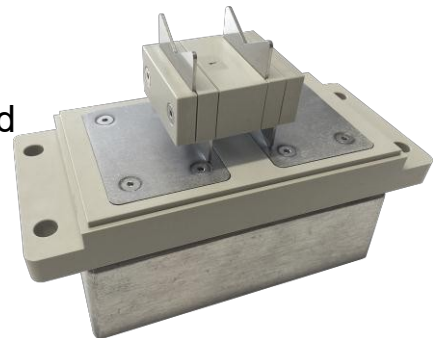

13. Photos for selection of right calibration curve

Wood chips



Wood chips



Coarse wood chips



Industrial wood chips



15. Exemption from liability

For missreadings and wrong measurements and of this resulting damage we refuse any liability. This is a device for quick determination of moisture. The moisture depends on multiple conditions and multiple materials. Therefore we recommend a plausibility check of the measuring results. Each device includes a serial number and the guarantee stamp. If those are broken, no claims for guarantee can be made. In case of a faulty device, please contact Schaller GmbH (www.humimeter.com) or your dealer.

16. Technical data

16.1. BLO material moisture sensor

Moisture measuring range: 10 to 55 % absolute material moisture
Temperature of material: 0 to 70 °C
Surrounding temperature: -10 to 70 °C
Protection class: IP 67

16.2. humimeter BLO control unit

Power supply voltage: 24VDC (optional 230VAC)
Current consumption: approx. 100mA & analogue output
Surrounding temperature: 0 – 50 °C
Protection class: IP 54

17. Device maintenance instructions

- Please always keep in mind that the moisture sensors are sensitive measuring instruments and handle them **WITH CAUTION**.
- If the measuring system doesn't work properly, please first of all reboot the system.
- The sensor has to be cleaned from pollution or something similar periodically.
- **DON'T BEND THE CABLE OF THE SENSOR.** We recommend the installation of a protection as the sensor may be damaged if the cable is bended too often.
- Wrong pin allocations may destroy the sensor and the control unit!
This is no case of warranty.

18. Most common reasons for miss readings

- When there is no material above the sensor, the air value is displayed (5.5).
- Water drops due to condensation on the measuring surface of the sensor
- Temperature (of material or surroundings) out of specified range. In general the accuracy decreases with rising temperatures due to a higher compensation factor.
- The pressure between sensor and material is too low.
- The cables must not lie in the area of electro-magnetic interference fields.
- The sensor is heavily soiled and needs to be cleaned.
- The sensor connector is not connected.
- The humimeter control unit has not been switched on or the sensor is not connected.
- The fuse for the control unit (ONLY AT 230VAC VERSION! 500mA fast acting) is defective. **It is ESSENTIAL to disconnect the control unit from power supply before changing the fuse!!!**
- Before opening the control unit, please get in contact with Schaller GmbH in order to clarify possible errors previously.
- **ATTENTION: The BLO control unit has to be connected to the grounding of the plant (see menu item 4.1)**